

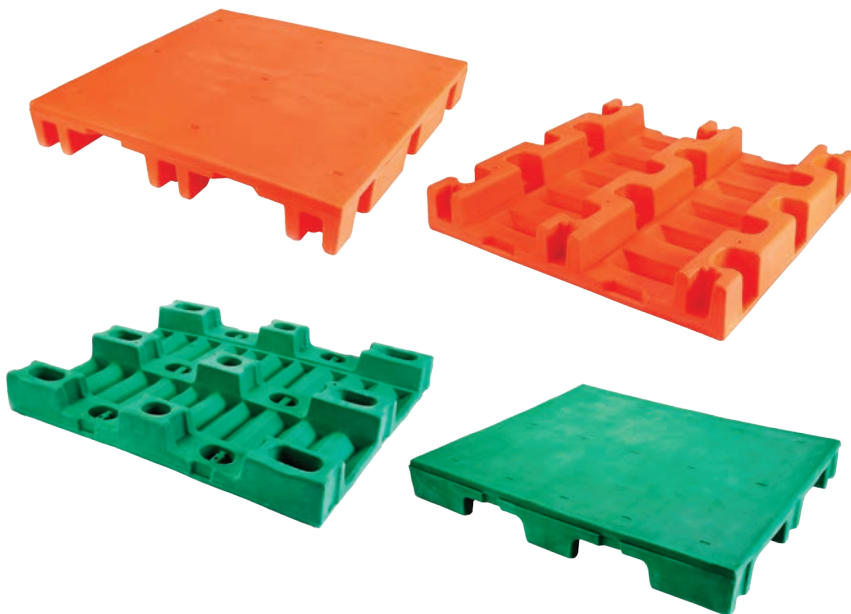

TUFF SERIES PALLET

ROTATIONALLY MOLDED
DURABLE PALLETS



EPI Pallet Advantages

- No nails, splinters, fungus, or bugs
- FDA-approved materials available
- Seamless design for sanitary applications
- Two-way or four-way forklift access
- Several color options
- Weight capacities based on application and rack systems
- Optional outer raised edge around pallet perimeter
- Optional anti-rollover straps molded in for durability
- Optional steel reinforcement available

TWO-WAY FORKLIFT ACCESS	40L x 48W	Flat Top
--------------------------------	-----------	----------

FOUR-WAY FORKLIFT ACCESS	40L x 48W	Flat Top
---------------------------------	-----------	----------

NEED A CUSTOM PALLET?

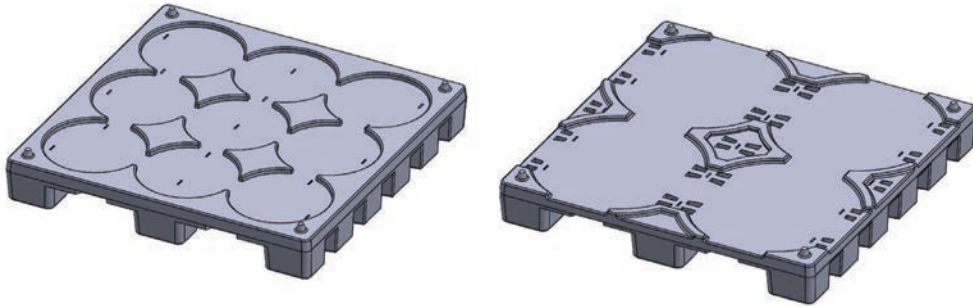

Custom Designs for Specific Applications

- Built to your size requirements
- Supports varying weight distributions
- Designed to stack safely
- Two-way and four-way pallet jack options

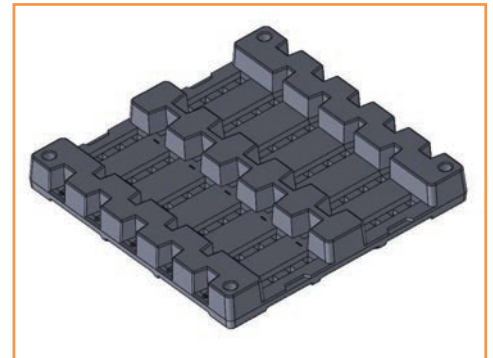

Elkhart Plastics, Inc. is a privately held American company founded in 1988. One of the largest custom rotational molders in the U.S., we have six facilities and more than 500 employees nationwide.

In addition to Pallets, Elkhart Plastics manufactures TUFF Series IBCs, KONG Coolers, Connect-a-Dock, and custom rotationally molded products for customers in industries including agriculture, chemicals, food processing, material handling, automotive, marine, and more.

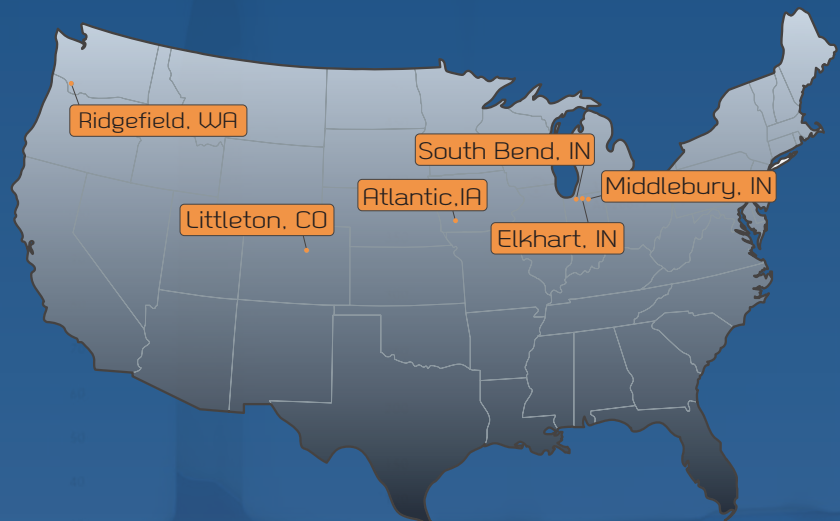

How can we work together? Contact EPI today!